

EASTMAN®

BLUE STREAK® II Model 629X

BRUTE Model 627X

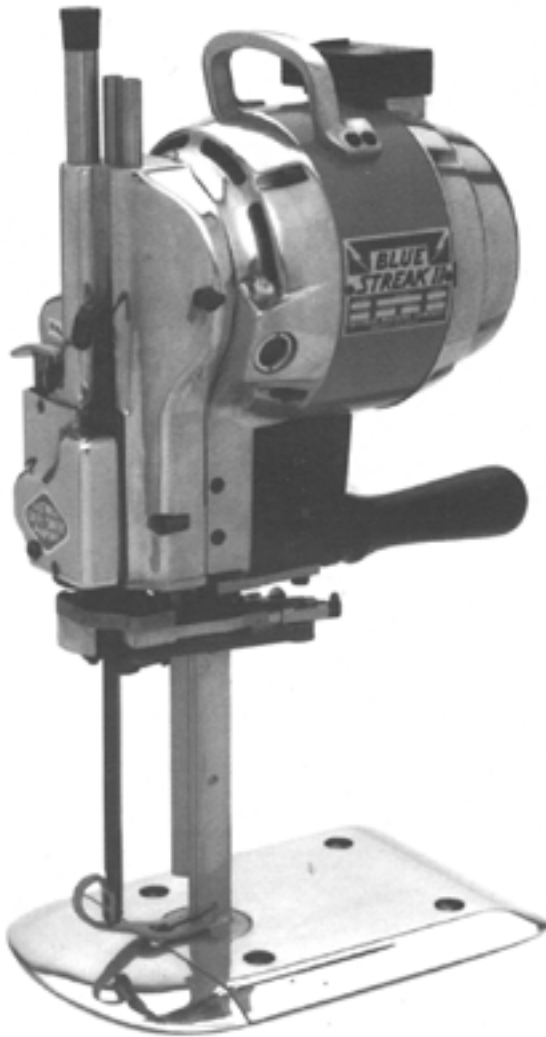

Instruction Manual

Blue Streak II Model 629X

Brute Model 627X

Serial # _____

⚠ WARNING

This machine is equipped with a very sharp knife. Keep hands, arms, and hair away from the knife area at all times.

Misuse of this machine or failure to follow all safety instructions on this machine and in the instruction manual may result in serious personal injuries.

Eastmanmachine
COMPANY

Table of Contents

Safety Information	1	Adjusting the Belt Sharpener	7
General Safety Precautions	1	Changing Sharpener Belts	7
Operation	2	Adjusting Stabilizers for Central Alignment	7
Initial Set Up	2	Checking the Sharpener Shoes	8
Operating Procedure	3	Checking the Extreme Down Position of the Sharpener	8
Safety Considerations	3	Checking the Stop Screw on the Sharpener Shoe	9
Starting the Machine	4	Check the Width of the Bevel on the Knife	9
Making a Cut	4	Changing the Knife	9
Turning Off the Machine	4	Adjusting Bevel Bloc® Shoes	11
Routine Maintenance	4	Troubleshooting	14
Care of the Machine	4	Freeing Frozen Guides	16
Daily	4	Accessories	16
Twice Weekly	4	Metal Mesh Gloves	16
Weekly	5	Ordering Details	17
Lubrication	5	Genuine Eastman Abrasive Belts	17
Daily	5	Ergo-Handle	18
Weekly	5	Specialty Machines	19
Monthly	5	Plastic Master Model 627PM/629PM	19
Sharpening the Knife	5	Micro Fog Model 627MF/629MF	19
Removing the Sharpener	5		
Replacing the Rubber Driver Pulley	6		

IMPORTANT

This manual contains instructions and part numbers for two different machines: Brute Model 627 and Blue Streak II Model 629. If you contact Eastman Machine Company for information or to order parts, always specify the machine name and model number.

If you are ordering electrical components, specify the voltage, frequency (Hz), and speed (RPM) of your machine. You can find this information on a label attached to your machine.

Patents Statement

Some parts of this manual and the equipment it describes are protected by the following U.S. patents: 5,178,232, 4,609,244, 5,111,582, 4,761,878, and D281,416. Other patents pending.

Trademarks Statement

The names Eastman, Uni-Safe, Blue Streak, and Bevel Bloc are registered trademarks of the Eastman Machine Company.

Eastmanmachine
COMPANY

Safety Information

Throughout this manual, safety information is presented by use of the terms *Warning*, *Caution*, and *Note*. These terms have the following meanings:

WARNING

A warning contains critical information regarding potential safety hazards that can occur during proper use or misuse of the machine. Failure to follow these procedures may result in serious personal injury to the user.

CAUTION

A caution contains instructions for the use or maintenance of the machine. Failure to follow these procedures may result in damage to the machine.

Supplementary information may be given in a *Note*.

Safety and Indemnification

During the life of the machine, the purchaser agrees to provide to all machine users (including its own employees and independent contractors) all relevant safety information, including warning labels and instruction manuals. The purchaser also agrees to maintain the safety features and working condition of the machine, and to adequately train all users in the safe use and maintenance of the machine. The purchaser agrees to defend, protect, indemnify, and hold Eastman Machine Company harmless from and against all claims, losses, expenses, damages, and liabilities to the extent that they have been caused by the purchaser's failure to comply with the terms and instructions of this manual.

General Safety Precautions

WARNING

- This machine is equipped with a very sharp and dangerous knife. Keep hands, arms, and hair away from the knife area at all times. When the machine is not in use, keep the pressure foot knife guard lowered and locked at all times. Safety gloves and glasses and appropriate clothing may prevent serious personal injuries.
- Disconnect the power supply from the machine when it is not in use or during routine maintenance, including lubrication.
- The purchaser must instruct all operators in the proper use of the machine according to the instructions on the machine and in this manual. This training must include instruction on the potential safety hazards arising from the use or misuse of the machine. In addition to such training, the purchaser should provide written work instructions as necessary to ensure correct use of the machine for specific cutting applications.
- The purchaser must provide appropriate safety measures and equipment as recommended in this manual. Observe all statutory requirements concerning the use of hazardous machinery that apply to your location.
- Do not modify this machine or disable safety features. Unauthorized modification may result in serious personal injuries to the user. Electrical connections to this machine must be made by a qualified electrician familiar with applicable codes and regulations. To prevent electrocution, a ground lead must be connected to terminal "E" on the attachment plug.
- This machine is intended ONLY for hand-held operation. Misuse of this machine or use of this machine as part of another machine may result in serious personal injuries to the user.
- Safety labels must be kept clean and legible at all times. Call the Eastman Machine factory to order replacement labels.

Operation

Before operating the machine, read these instructions carefully. Familiarize yourself with all the functions and adjustments of the machine.



Figure 1. Operating Features

Initial Set Up

After the machine has been installed and before you use it for the first time:

1. Check that the electrical supply current and voltage that the machine is connected to are the same as stamped on its name plate. For three-phase machines, also check that the direction of rotation is correctly set by the turning knob (Figure 2, F). Refer to the tag attached to all three-phase machines for detailed instructions.

CAUTION

Operating this machine from an incorrect electrical supply may damage it.

2. Check that the machine has been lubricated according to the schedule listed in *Routine Maintenance—Lubrication* on page 5.

Note: At this time, carry out the full monthly lubrication schedule on page 5.

3. Make sure that the sharpener is in the locked position. To do this, push in the turning knob (Figure 2, F). While depressing the turning knob, turn the machine over a few revolutions by hand to see if the knife reciprocates easily. If the knife does not move easily, the sharpener may be in the unlocked position.
4. To lock the sharpener in place, lift the release lever (Figure 2, D) and press the sharpener lever (Figure 2, E) to release the sharpener. Raise the sharpener bracket (Figure 2, S) by hand to lock it in place. Once the sharpener is locked in place, you may disengage the release lever and sharpener lever. Repeat step 3 to ensure that the sharpener is now locked. If not, repeat this step.
5. Visually inspect the blade to ensure that the top of the knife is flush with the knife lockbolt (Figure 7, 1 on page 9) and that the knife is perpendicular to the baseplate. If you need to adjust the alignment of the blade, see section *Changing the Knife* on page 9.
6. Check that the motor switch is in the OFF position. Then connect the attachment plug to the terminal block on the machine.
7. Hold the operating handle and turn on the machine. Allow the blade to reach full speed. If the blade is struggling, the sharpener is still not in the locked position. If this is the case, turn off the machine and do the following:

7.1 With your left hand, straddle the front of the sharpener with fingers and thumb.

7.2 Press the bell crank release lever (Figure 2, H) to disengage the sharpener mechanism from the motor.

7.3 With your right hand, hold the operating handle and turn on the motor switch. Allow the motor to gather full speed and then release the release lever. This automatically returns the sharpener to the locked position.

CAUTION

Turn the motor on and off a few times before running the machine continuously. This permits the oil to warm up and flow easily into the close-fitting moving parts. Failure to do this may result in damage to your machine.

The machine is now ready for use.

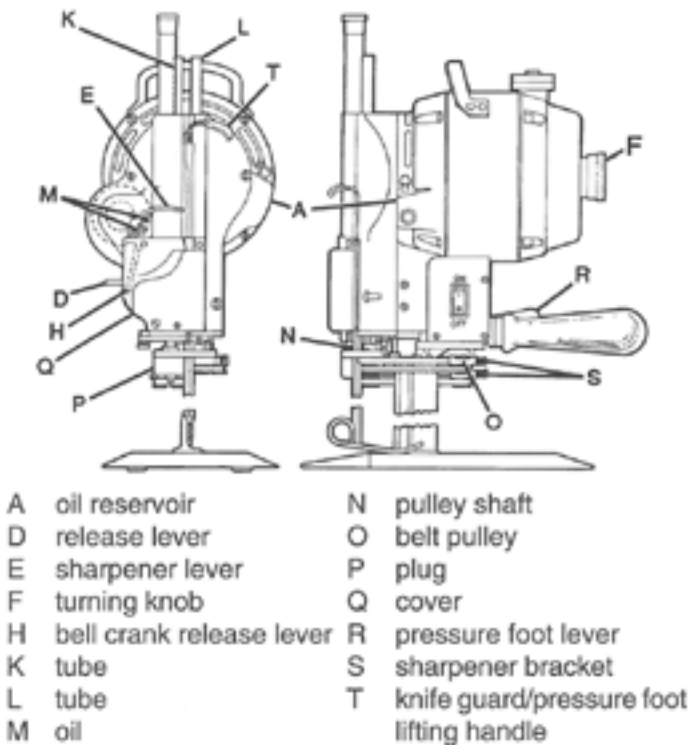

Figure 2. Controls and Adjustments

Operating Procedure

Safety Considerations

WARNING

To prevent serious injury, read and follow these safety precautions.

Before starting or using your machine:

1. Check that you know and understand the following:
 - That proper voltage is supplied to machine.
 - How to turn off the machine in an emergency.
 - The meaning of all warning labels on the machine.
 - What happens to the machine when you operate the controls.
 - Proper start-up procedures described in Initial Set Up section.
 - What to do in the event of a jam or other unforeseen situation.
 - How to disconnect power from the machine.

If you are not familiar with any of these points, ask your supervisor or contact an Eastman representative.

2. Check the condition of your machine and working area. Make sure that:
 - There is no visible damage to the machine. Pay particular attention to the blade.
 - No maintenance work is currently being performed in your working area.
 - No unnecessary people are in your working area.
 - Your working area is clear of debris, spilled liquids, food, drink, or other obstructions.
 - Your clothing, hair, and jewelry cannot snag or become tangled in the machine. Wear appropriate protective equipment as necessary. Remove all rings, watches, neckties, and other loose objects. Tie up hair or wear a hair net.

If you are uncertain about any of these points, do NOT use the machine.

WARNING

Failure to use all recommended safety measures and equipment may result in serious personal injury.

Starting the Machine

If you have had the machine less than one month or if it has stood idle for any length of time, turn the motor on and off a few times before running it continuously. This permits the oil to warm up and flow easily into the close-fitting moving parts.

CAUTION

Failure to warm up your machine adequately may damage the motor.

Making a Cut

WARNING

Failure to keep hands, arms, and hair away from the knife area at all times may result in serious personal injury.

1. Bring the machine up to the material spread.
2. Raise the knife guard/pressure foot by depressing the pressure foot lever (Figure 2, R) and lifting the knife guard/pressure foot lifting handle (Figure 2, T). Raise the pressure foot only enough to clear the material being cut.
3. Turn on the machine, allow the blade to reach full speed, and enter the fabric.
4. Using the pressure foot lever (Figure 2, R) and the knife guard/pressure foot lifting handle (Figure 2, T), lower the pressure foot so that it is slightly above the material being cut. This will prevent the material from reciprocating.
5. Begin cutting.
6. When you are not making a cut, or when the machine is not in use, keep the knife guard/pressure foot lowered to the baseplate by depressing the pressure foot lever (Figure 2, R).
7. Turn off the machine when not cutting fabric.

Turning Off the Machine

When you have finished using your machine:

1. Position the power switch to off.
2. Make sure the knife guard/pressure foot is lowered to the baseplate by depressing the pressure foot lever (Figure 2, R).
3. Disconnect the attachment plug from the power source.
4. In cold weather, ensure that the machine is kept in a warm place when not in use.

Routine Maintenance

WARNING

Always unplug the machine before performing maintenance, adjustments, or repairs.

WARNING

After servicing the machine, always make sure the plate bolt nut is securely fastened (Figure 3, X on page 6) before resuming cutting operation.

Care of the Machine

To ensure proper operation of your machine, carry out the following procedures at the intervals indicated. If you use your machine intensively, consider performing these procedures more often.

Daily

Remove the knife and clean the knife slides with the slot cleaner (Figure 7, 2 on page 9) included with machine. To prevent undue accumulation of lint, do NOT oil the plate rollers. If the rollers stick, remove them from the plate and wash them in cleaning solvent.

Twice Weekly

Use an approved air hose or bellows to blow any lint from around the motor and sharpener.

⚠ WARNING

Failure to wear eye protection when using air hose or bellows may result in serious eye or facial injuries.

Weekly

Remove the cover (Figure 2, Q) and clean any lint from around the screw mechanism in the sharpener.

Lubrication

Lubricate your machine according to the following schedule:

⚠ CAUTION

Use only specially compounded Eastman 30-weight, non-detergent oil. Use of sewing machine oil or detergent oil may result in damage to your machine. Do not oil the baseplate rollers. Use of an excessive amount of oil may damage the machine.

Daily

1. Place two drops of oil at each of the two locations shown in Figure 2, M. Use an oil can with a small spout. (A suitable oil can is furnished with the machine.)
2. Fill the oil reservoir (Figure 2, A) for continuous use. If you only use the machine intermittently, you can use less oil.

Weekly

1. Carry out the *Daily* lubrication schedule above.
2. Apply one drop of oil only to each of the following:
 - Tubes at locations shown as Figure 2, K and L.
 - Pulley shaft shown as Figure 2, N.
 - Belt pulley shown as Figure 2, O.

Monthly

1. Carry out the *Daily* and *Weekly* lubrication schedules above.

2. Remove the plug (Figure 2, P) and insert a grease tube. Squeeze an amount of grease approximately the size of a pea into the opening.

⚠ WARNING

Routinely check the tightness of the operating handle to ensure a secure connection.

Sharpening the Knife

Sharpen the knife at frequent intervals or whenever you feel it is not cutting adequately:

1. Take the machine out of the lay.
2. Drop the knife guard/pressure foot using the pressure foot lever (Figure 2, R on page 3), located next to the machine operating handle.
3. Press the sharpener lever (Figure 2, E) downward with a slow, firm pressure to engage the sharpening mechanism. Too fast a lever action may cause the lever to lock. If this occurs, lift the release lever (Figure 2, D) and start over again.

Removing the Sharpener

1. Disconnect the machine from the power source.
2. Using the turning knob (Figure 2, F) raise the blade to top position.
3. Press the sharpener lever (Figure 3, E on page 6) approximately halfway down and to the neutral position, and lower the sharpener by hand.

⚠ WARNING

This machine is equipped with a very sharp knife. Remove the knife when working in this area. Failure to keep hands, arms, and hair away from the knife area may result in serious personal injury.

4. Remove the back guide (Figure 3).

5. Press the lever (Figure 3, E) to a neutral position and raise the sharpener to the top (original) position.
6. Remove the four hold-down nuts (Figure 3, V) and remove the sharpener.

Note: If you press the sharpener lever (Figure 3, E) down too far (beyond the neutral position), it will lock the sharpener bracket. If this occurs, lift the release lever (Figure 3, D) and start over again.

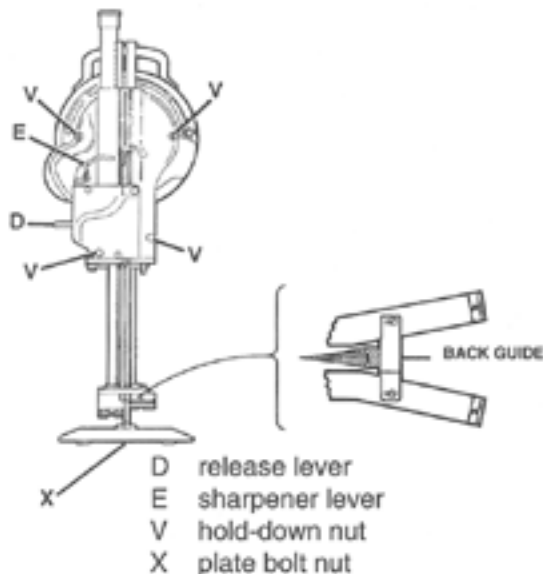
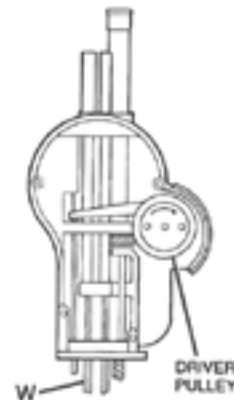

Figure 3. Removing the Sharpener

Replacing the Rubber Driver Pulley

The sharpener is driven by a rubber driver pulley, as shown in Figure 4. Replace this driver pulley whenever it appears to be worn or damaged, as follows:

1. Remove the sharpener from the machine (see *Removing the Sharpener* on page 5).
2. Press the sharpener lever (Figure 3, E) to a neutral position and lower the sharpener until an inch of the square shaft (Figure 4, W) is exposed.



W square shaft

Figure 4. Replacing the Rubber Driver Pulley

3. Hold the square shaft with a wrench. Position the wrench as close as possible on the shaft to the sharpener housing.
4. Use a spanner wrench to remove the driver pulley by turning it clockwise as indicated by the arrow in Figure 4.

Note: The pulley has a left-hand thread.

5. Reassemble the new pulley on the sharpener.
6. Reassemble the sharpener on the machine.

Adjusting the Belt Sharpener

Note: You can obtain all the special tools you will require for adjusting the sharpener by ordering tool kit #820C2.

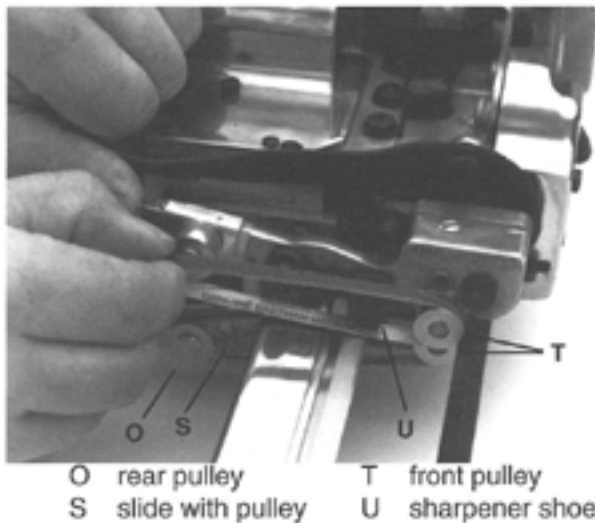

Figure 5. Changing the Sharpener Belts

⚠ WARNING

Failure to unplug the attachment plug from the power source before performing maintenance may result in serious personal injury.

Changing Sharpener Belts

1. Push the slide with pulley (Figure 5, S) inward to relieve tension, then remove the worn belt.
2. Place the new belt over the front pulley (Figure 5, T), then between the sharpener shoe (Figure 5, U), and then over the rear pulley (Figure 5, O).
3. Release the slide with pulley.

Note: Sharpener belts are available in four grits: Rough, Coarse, Medium, and Fine. See *Abrasive Belt Grits* on pages 17-18 for ordering information.

Adjusting Stabilizers for Central Alignment

1. Disengage the attachment plug, if you have not already done this.
2. Depress the sharpener lever (Figure 2, E on page 3) halfway and lower the belt carrier to the extreme bottom position.
3. Loosen the screws (Figure 6, 1) and disengage the back guide (Figure 6, 6) from contact with the standard.
4. Loosen the screws (Figure 6, 2) and disengage the stabilizers (Figure 6, 4 and 5).

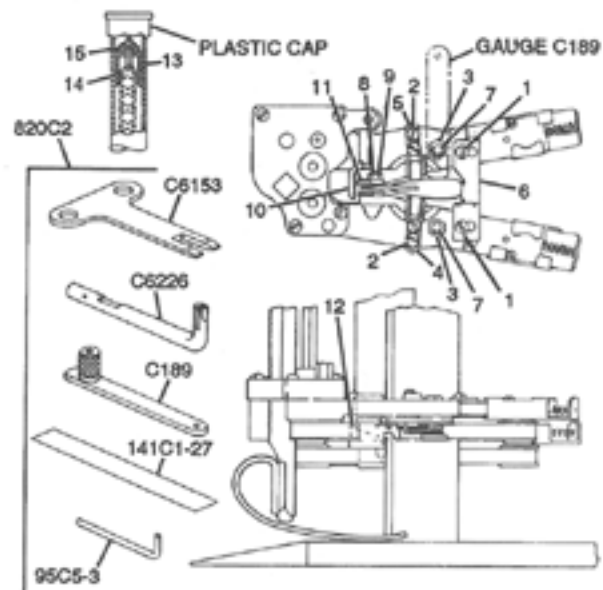

- | | |
|---------------|-------------------|
| 1 screw | 9 locknut |
| 2 screw | 10 clamping arm |
| 3 locknut | 11 sharpener shoe |
| 4 stabilizer | 12 shoe |
| 5 stabilizer | 13 tube |
| 6 back guide | 14 spacer |
| 7 pivot screw | 15 locknut |
| 8 stop screw | |

Figure 6. Adjusting the Stabilizers

5. Remove the locknut (Figure 6, 3).
6. Install gauge C189 on the exposed threaded end of the pivot screw (Figure 6, 7) and press the end of the gauge against the side of the standard.
7. Holding this position, engage the opposite stabilizer (Figure 6, 4) firmly against the side of the standard and tighten the screws (Figure 6, 2).
8. Remove tool C189 and press the positioned stabilizer (Figure 6, 4) against the side of the standard. Then fasten the opposite stabilizer (Figure 6, 5) firmly against the standard.
9. Re-engage the back guide (Figure 6, 6) in loose contact with the back of the standard.

Checking the Sharpener Shoes

The shoes should swing in and out freely without excessive up and down play. If adjustment is necessary, proceed as follows:

1. Loosen the locknuts (Figure 6, 3) and tighten the screws (Figure 6, 7) as required.
2. Check the clamping arm (Figure 6, 10) with the belt carrier in the most downward position and the knife in the most upward position. The clamping arm should keep the sharpener shoe from moving in. If it fails to do so, the serrations on the clamping arm are worn or the sharpener shoe (Figure 6, 11) is worn.
3. Replace worn part(s) as necessary.

Checking the Extreme Down Position of the Sharpener

The correct down position is with the tip of the knife at the center of the belt on the shoe (Figure 6, 12). The belt should be in the most downward position, and the knife should be in the most upward position. If the belts are too high, the bottom point of the knife will not sharpen. If the belts are too low, the bottom point of the knife will round off excessively. If adjustment is necessary:

1. Raise the belt carrier to the up position.
2. Remove the plastic cap from the tube for the screw shaft.
3. Insert a pin through the hole in the tube (Figure 6, 13) to prevent the spacer (Figure 6, 14) from turning. Then remove the locknut (Figure 6, 15).

The following step describes the correct procedure for setting spacer adjustment on different stroke machines:

Note: Prior to beginning adjustment, be sure that the spacer is threaded fully onto screw shaft.

Stroke	Turns
1-1/8"	11
1-1/4"	9
1-1/2"	13
1-3/4"	8
Note: Each turn = 1/32"	

4. Turn the spacer clockwise with wrench C6153 to raise the bottom position, or turn counter-clockwise to lower the position.

Note: One turn in either direction adjusts the position by 1/32".

5. When the spacer is adjusted, use the pin to hold the spacer in position, reassemble, and tighten the locknut (Figure 6, 15).
6. Replace the plastic cap.

Checking the Stop Screw on the Sharpener Shoe

1. With new belts on the carrier, insert .010 feeler gauge #141C1-27 between the stop screw (Figure 6, 8) and the knife. Ensure that the clamping arm (Figure 6, 10) has been released from the sharpener shoe (Figure 6, 11). The gauge should just fill the space between the screw and the knife.
2. If an adjustment is necessary, loosen the locknut (Figure 6, 9). Adjust the set screw to the proper spacing, and re-tighten the locknut.

Check the Width of the Bevel on the Knife

The bevel should be approximately 1/16" on both sides. If it is not:

1. Install a new knife and new belts.
2. Color the bevel with a wax pencil.
3. Run the sharpener up and down the knife several times.
4. If an adjustment is required for Flex-Pad shoes, insert tool C6226 over the belt guide pad. Move the free end of the tool to the rear to increase the bevel, or to the front to decrease bevel.

Changing the Knife



WARNING

Always handle knives with care. Safely dispose of used knives.

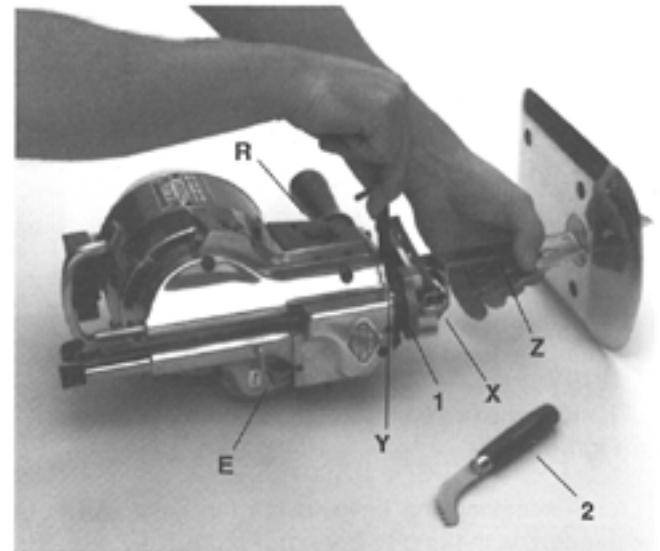

- | | | | |
|---|----------------|---|----------------------------|
| 1 | knife lockbolt | R | pressure foot lever |
| 2 | slot cleaner | X | pressure foot |
| E | lever | Y | T-handle knife bolt wrench |
| | | Z | standard |

Figure 7. Changing the Knife

Changing the Knife (continued)

⚠ WARNING

Unplug the attachment plug from power source.

1. Make sure the sharpener is in the locked position.
2. Raise the pressure foot (Figure 7, X on page 9) to the top position using the pressure foot lever (Figure 7, R), which is located next to the machine operating handle.
3. Lay the machine on a table, as shown in Figure 7.
4. Press in the turning knob (Figure 2, F on page 3) and turn the knife to the bottom position.
5. Insert the T-handle knife bolt wrench (Figure 7, Y) and loosen the knife lockbolt (Figure 7, 1).
6. Remove the knife through the bottom of the standard (Figure 7, Z).
7. After removing the knife, clean the knife slot in the standard with the slot cleaner (Figure 7, 2).
8. Insert a new knife in the knife slot. Be sure to set the knife tightly against the knife lockbolt. Hold the bottom of the knife against the back of the slot in the standard and tighten the knife lockbolt.

9. After tightening the knife lockbolt, check to see if the knife runs freely in the standard by rotating the turning knob.
10. Install new sharpener belts and operate the sharpener three or four times before starting to cut.

Note: For best results, use only Eastman knives. The limited warranty covering your machine is not valid if you use knives other than those manufactured by Eastman. The available knives and accessories are shown in Figure 8 and in the selection charts on the next page.

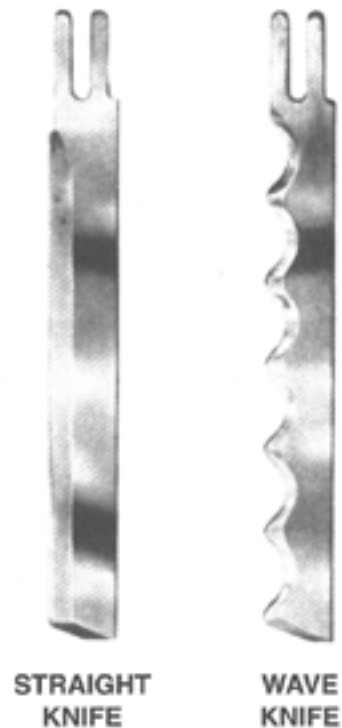

Figure 8. Available Eastman Knife Types

WAVE KNIVES REQUIRE SPECIAL SHOES AND RELATED PARTS LISTED BELOW

743C1-27	L.H. Shoe	743C1-26	R.H. Shoe
34C10-47	L.H. Spring	34C10-57	R.H. Spring
20C12-57	Screw (for shoe)	20C12-57	Screw (for shoe)

WHEN USING THESE SPECIAL SHOES, THE FOLLOWING PARTS MUST BE REMOVED FROM THE LOWER GEAR BRACKET

35C7-28	Clamping Arm	See page 21
34C10-123	Spring	
20C12-143	Screw	

See page 20 for slow speed drive note.

STRAIGHT KNIFE SELECTION CHART

CARBON STEEL				HIGH-SPEED STEEL					SPECIAL PROCESS
KNIFE SIZE	STRAIGHT FRONT	SAW TOOTH	WAVE EDGE	STRAIGHT FRONT	ROUND TIP	ANGLE TIP	SAW TOOTH	WAVE EDGE	STRAIGHT FRONT
4	80C4	80C4-14	80C4-19	80C4HS			80C4-14HS	80C4-19HS	
5	80C5	80C5-14	80C5-19	80C5HS	80C5HS-R	80C5-36HS	80C5-14HS	80C5-19HS	80C5SP
6	80C6	80C6-14	80C6-19	80C6HS	80C6HS-R	80C6-36HS	80C6-14HS	80C6-19HS	80C6SP
7	80C7	80C7-14	80C7-19	80C7HS	80C7HS-R	80C7-36HS		80C7-19HS	80C7SP
8	80C8	80C8-14	80C8-19	80C8HS	80C8HS-R	80C8-36HS		80C8-19HS	80C8SP
9	80C9		80C9-19	80C9HS	80C9HS-R	80C9-36HS		80C9-19HS	80C9SP
10	80C10		80C10-19	80C10HS	80C10HS-R	80C10-36HS		80C10-19HS	80C10SP
11-1/2	80C11-1/2			80C11-1/2HS	80C11-1/2HS-R	80C11-1/2-36HS		80C11-1/2-19HS	80C11-1/2SP
13	80C13			80C13HS	80C13HS-R				80C13SP

80C6-47HS 6" High-Speed Wave Special Grooved Knives for Micro Fog Machine
 80C7-47HS 7" High-Speed Wave Special Grooved Knives for Micro Fog Machine

Teflon-coated knives available. Order by adding "T" to end of knife order.

Adjusting Bevel Bloc® Shoes

Eastman's exclusive, patented adjustable Bevel Bloc sharpener shoes make it possible to grind any desired bevel on the knife edge. The knife-edge bevel on your new machine is factory set to handle all normal fabrics and normally should not be changed. The preset measurement is 1/16" wide.

(Continued on next page.)

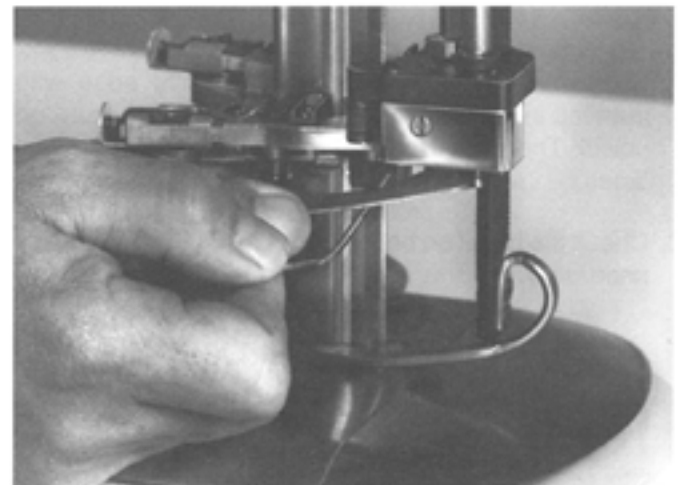

Figure 9. Adjusting Bevel Bloc Shoes

Eastmanmachine
 COMPANY

Adjusting Bevel Bloc® Shoes (continued)

If you need to adjust the bevel on the knife edge to a different length, proceed as follows:

1. Disconnect the machine from the power source.
2. Lower the knife to the bottom of the stroke with the machine turning knob (Figure 2, F on page 3).
3. Lower the sharpener manually, by holding the sharpener lever (Figure 2, E) halfway down to its neutral position.
4. Pull the sharpener belt down to expose the set screw (Figure 9 on page 11) on the Bevel Bloc.
5. Insert Allen wrench 95C5-5 into the set screw and loosen it slightly.
6. For a longer bevel on the knife edge, move the key and bloc to the rear. For a shorter bevel, move them to the front.
7. Re-tighten the set screw.
8. Adjust the Bevel Blocs on both shoes.
9. Return the sharpener to the top (locked) position.
10. Check the stop screws on the sharpener shoes for correct setting, as described in *Checking the Stop Screw on the Sharpener Shoe* on page 9.
11. Color-mark the front sides of the knife edge with marking ink or a wax pencil. Reconnect and turn on power. Then move the sharpener down and up several times.
12. Check the bevel on both sides of the knife. Readjust if necessary.

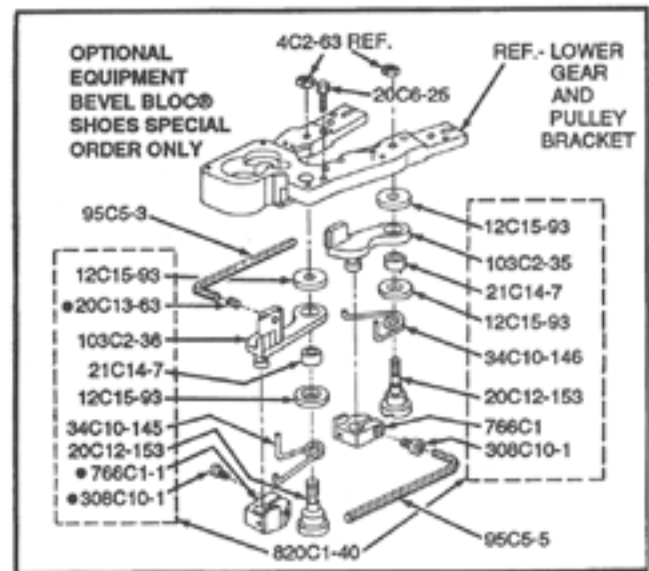

Figure 10. Bevel Bloc Shoe Assembly

SUBASSEMBLY 743C3-1 INCLUDES:

20C13-63	Screw, Set
103C2-36	Shoe, Sharpener L.H.
766C1-1	Bevel Bloc Assembly L.H.
308C10-1	Screw, Socket 6/32" x 5/16" (2 required)

PART NO. DESCRIPTION

4C2-63	L.H. Nut (2 required)
715C1-16	Lower Gear Bracket Complete 5"-10" Knife
715C1-18	Lwr. Gear Bracket Com. 11 1/2"-13" Knife
820C1-40	Conversion Kit R.H. & L.H. Shoes

INCLUDES THE FOLLOWING:

12C15-93	Washer Shoe (4 required)
20C6-25*	Screw Adjust
20C12-153	Screw, Sharpener Shoe (2 required)
20C13-63	Screw, Set
21C14-7	Bushing, Shoe (2 required)
34C10-145	Spring Shoe L.H.
34C10-146	Spring Shoe R.H.
95C5-3	Wrench, Allen
95C5-5*	Wrench, Allen
103C2-35	Shoe, Sharpener R.H.
103C2-36	Shoe, Sharpener L.H.
308C10-1*	Screw, Socket 6/32" x 5/16" (2 required)
766C1*	Bevel Block Assembly R.H.
766C1-1*	Bevel Block Assembly L.H.
820C1-39	Conversion Kit includes * parts above.

Note: 766C1 and 766C1-1 are sold in pairs with kits only.

SUBASSEMBLY 743C3 INCLUDES:

103C2-35	Shoe, Sharpener R.H.
766C1	Bevel Block Assembly R.H.
308C10-1	Screw, Socket 6/32" x 5/16" (2 required)

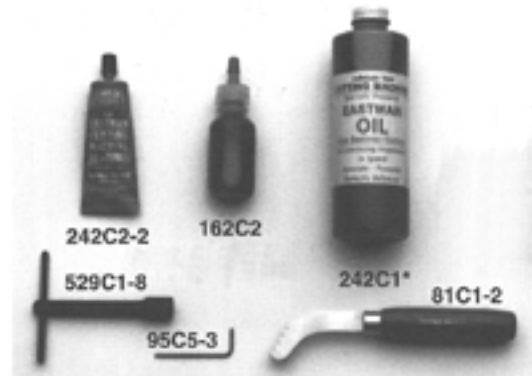

Figure 11. Maintenance Supplies for Bevel Bloc Shoes

MAINTENANCE SUPPLIES

PART NO.	DESCRIPTION
529C1-8	Knife Bolt Wrench
95C5-3	Allen Wrench for Shoe Set Screws
242C2-2	Eastman Bearing Grease
162C2	Oil Can
242C1*	1/2 Pint Eastman Oil
81C1-2	Slot Cleaner

*Optional

Troubleshooting

PROBLEM	SOLUTION
Motor overheats	<ul style="list-style-type: none"> a. Cut out switch not engaging properly b. Lint and dust inside motor cover c. Three-phase: one phase not working
Machine does not start	<ul style="list-style-type: none"> a. Connector not firmly attached to terminal pins b. Start switch defective c. Starting switch or cut-out switch and/or capacitor defective
Bottom corner of blade breaks	<ul style="list-style-type: none"> a. Knife slides badly worn b. Knife strikes throat plate.
Motor slow to attain top speed	<ul style="list-style-type: none"> a. Sharpener is engaged b. Cut out switch not adjusted properly c. Low or wrong voltage d. For three-phase machines: <ol style="list-style-type: none"> 1. Fuse out on one phase 2. Ground wire incorrectly connected to machine
Motor slows in a certain position	<ul style="list-style-type: none"> a. Crosshead and guides tight b. Standard not in alignment with crosshead c. Standard bent
Motor rotates in wrong direction	<ul style="list-style-type: none"> a. Three-phase: incorrect wiring
Terminal block and/or electrical connector overheats	<ul style="list-style-type: none"> a. Inserts in connector worn. Change connector. b. Terminal pins worn

PROBLEM	SOLUTION
Machine does not move easily on table	<ul style="list-style-type: none"> a. Surface of cutting table not smooth b. Rubber mounted rollers compressed causing baseplate to drag on table
No bevel on one side of blade	<ul style="list-style-type: none"> a. Broken torsion spring b. Band plates do not pivot freely
Sharpener belt cut off by blade	<ul style="list-style-type: none"> a. Refer to page 8, <i>Checking the Extreme Down Position of the Sharpener</i>
Pressure foot rod does not move freely	<ul style="list-style-type: none"> a. Dirt in pressure foot lock bracket
Pressure foot rod does not hold	<ul style="list-style-type: none"> a. Lock loose on shaft b. Pressure foot handle spring broken c. Teeth worn on lock d. Screw loose
Sharpener runs slowly	<ul style="list-style-type: none"> a. Oil on crank b. Stabilizer assembly too tight against standard c. Worn pulley d. Worn screw shaft e. Add grease to lower gear bracket
Bevel very wide on both sides of blade	<ul style="list-style-type: none"> a. Worn sharpener shoes

ALL SINGLE PHASE
DUAL SPEED MACHINES

ALL SINGLE PHASE
SINGLE SPEED MACHINES

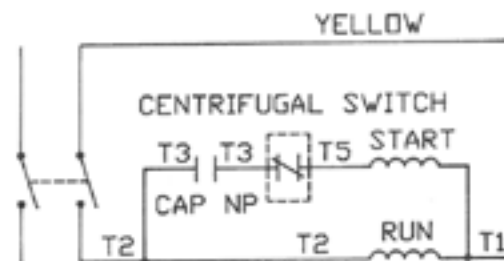
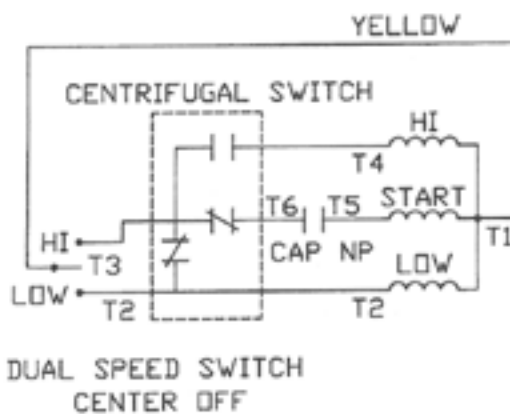
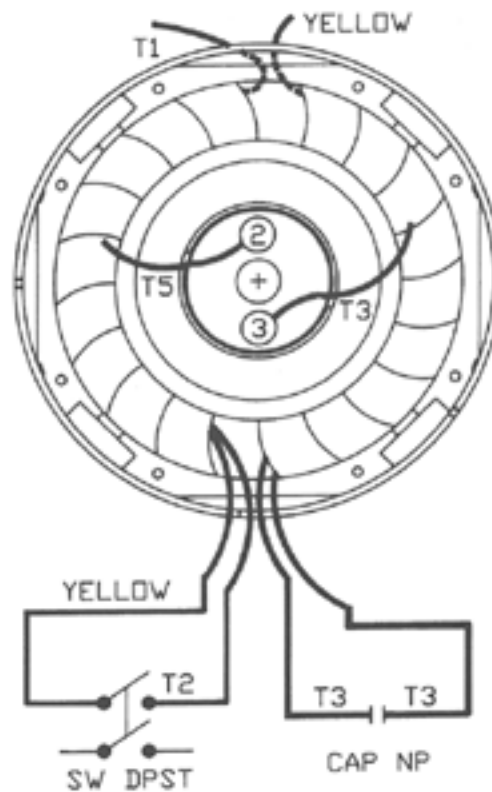
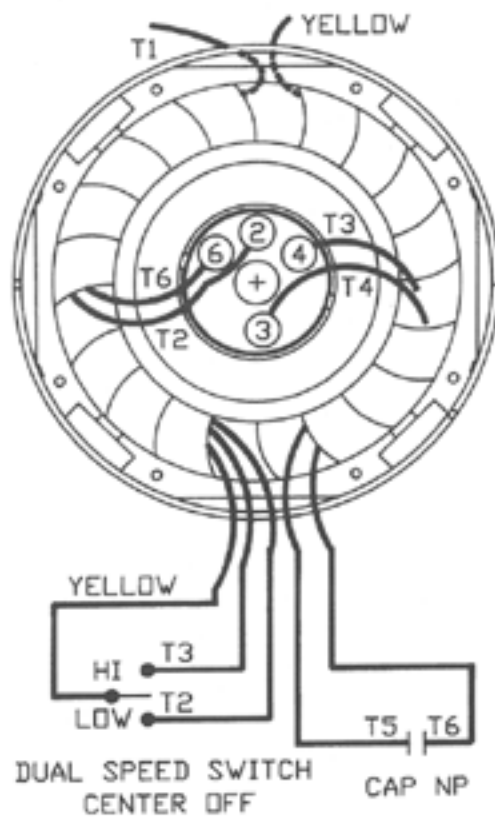

Figure 12. Single-Phase Electrical Configuration

Freeing Frozen Guides

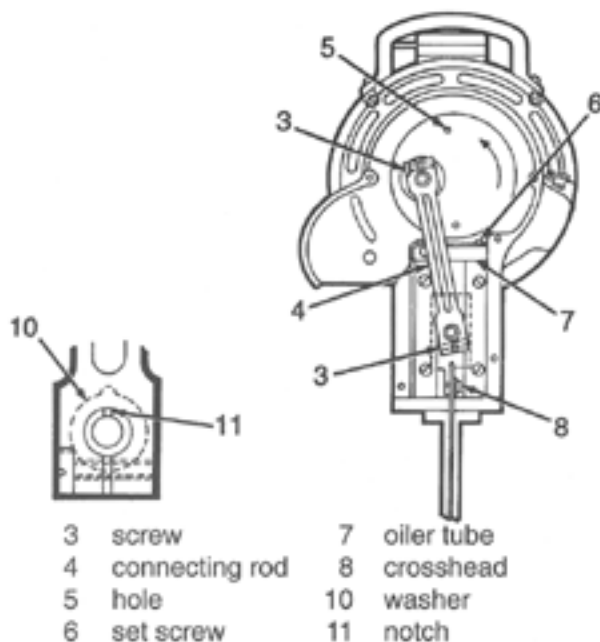

Figure 13. Freeing Frozen Guides

To free frozen guides, proceed as follows:

1. Remove the machine from the power source.
2. Remove the sharpener from the machine, see *Removing the Sharpener* on page 5.
3. Loosen the screws (Figure 13, 3) and remove the connecting rod (Figure 13, 4).
4. Insert the drift pin in the hole (Figure 13, 5) in the crank and tap with a light hammer in the direction of the arrow. This will loosen the crank.
5. Remove the crank.
6. Loosen the set screw (Figure 13, 6) using a No. 564 Allen key (.078 hex) and remove the oiler tube (Figure 13, 7).
7. Remove the crosshead (Figure 13, 8) from the guides.

8. Place a fiber or brass rod against the bottom of the crosshead and drive the crosshead out through the top of the guides.

Note: If the wrist pin is frozen in the crosshead, drive the wrist pin out of the crosshead with a soft punch. Polish the wrist pin and the hole in the crosshead with fine emery cloth.

9. Hone any rough spots on the bearing surface of the crosshead against a flat oilstone until smooth.
10. Examine the guides. If there is any evidence of a high spot, remove it with a scraper and then clean.
11. Oil the bearing surface of the guides, insert the crosshead, and reassemble the machine. Ensure the washer (Figure 13, 10) is in place between the connecting rod and crosshead.

CAUTION

The wrist pin must be installed with the notch (Figure 13, 11) at top center. If the wrist pin is not installed correctly, the flow of oil to the wrist pin bearing will be cut off.

12. Return power to machine and run the machine for approximately one-half hour, oiling the guides frequently, before putting the machine back into production.

Accessories

Metal Mesh Gloves

Metal mesh gloves provide an extra margin of safety when handling knives. Eastman has a range of comfortable, lightweight, and good-fitting gloves that offer complete freedom of movement. Mesh allows air circulation, so the hand doesn't sweat.

The all-metal, soldered construction provides maximum strength. They are available either with buckle strap or quick-release strap with Velcro closure.

**WARNING**

Metal mesh gloves provide protection from minor cuts, but will NOT prevent accidental injury. Even if you wear safety gloves, failure to keep hands, arms, and hair away from the knife area and follow the safety precautions on the machine and in this manual may result in serious personal injuries.

**WARNING**

Do not use metal mesh gloves with a round knife blade cutting machine. The circular motion of the knife could pull the glove towards the blade.



STYLE 515, 5 FINGER



STYLE 513, 3 FINGER

Figure 14. Available Metal Mesh Glove Styles

Ordering Details

All gloves are available with three or five fingers. Three-fingered gloves have an additional palm strap.

Note: Right-handed operators should order "Left-Hand" gloves. Left-handed operators should order "Right-Hand" gloves.

Ordering Reference	Description
Left-Hand (For Right-Handed Operators)	
AW 513 SL	3 Finger, small, Velcro
AW 513 SLS	3 Finger, small, Snap
AW 513 ML	3 Finger, medium, Velcro
AW 513 MLS	3 Finger, medium, Snap
AW 513 LL	3 Finger, large, Velcro
AW 513 LLL	3 Finger, extra large, Velcro
AW 515 SL	5 Finger, small, Velcro
AW 515 SLS	5 Finger, small, Snap
AW 515 ML	5 Finger, medium, Velcro
AW 515 ML	5 Finger, medium, Snap
AW 515 LL	5 Finger, large, Velcro
AW 515 LLS	5 Finger, large, Snap
AW 515 LLL	5 Finger, extra large, Velcro
Right Hand (For Left-Handed Operators)	
AW 513 MR	3 Finger, medium, Velcro
AW 513 RH	3 Finger, large, Velcro
AW 515 SR	5 Finger, small, Velcro
AW 515 MR	5 Finger, medium, Velcro
AW 515 LR	5 Finger, large, Velcro

Genuine Eastman Abrasive Belts

Eastman's four abrasive belt grits offer an edge for every fabric. For increased cutting efficiency, Eastman offers four different edges as produced by four different abrasive belts. These belt grits are available in convenient, color-coded boxes for easy identification.



Figure 15. Eastman Abrasive Belts

Eastmanmachine
COMPANY

The 250X microphotographs (Figure 16) show four different edges, as produced by Eastman's four abrasive belt grits.

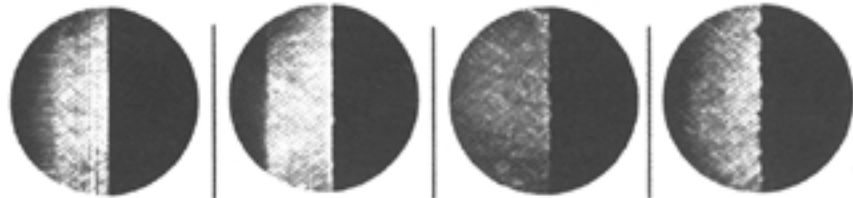

**FINE BELT
FINE EDGE**
Slices thru synthetics and blends, for knitted or loosely woven cloths, and for silks, high-pile fabrics, quilting, etc.
BLUE
181C2-5

**MEDIUM BELT
MEDIUM EDGE**
Shears thru the general run of rayons, cottons, light woollens, tropicals, suitings, and similar materials
GREEN
181C2-2

**COARSE BELT
COARSE EDGE**
For heavier weight variations of the "medium" materials at left, and for lightly woven cloths, pocketing, light denims, over-coatings, light leatherette, and rubberized fabrics
RED
181C2-1

**ROUGH BELT
ROUGH EDGE**
The edge that practically SAWS thru heavy denim, coated fabrics, treated canvas, simulated heavier leathers, etc. where the going gets tough!
BLACK
181C2-6

SPECIAL PERFORMANCE BELTS: Electrostatically Coated

FINE BELT	MEDIUM BELT	COARSE BELT
BLUE	GREEN	RED
181C2-5SP	181C2-2SP	181C2-1SP

Figure 16. Edges Produced by Different Belt Grits

Ergo-Handle

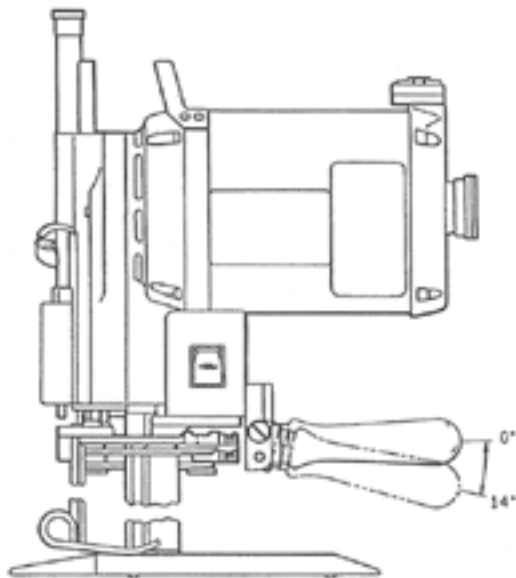

Figure 17. Ergo-Handle

Available as an option on new machines or for retrofitting to any existing Eastman straight knife, the Ergo-Handle allows the operator to adjust the handle downward from the standard horizontal through a 14-degree range. Adjusting the handle's angle to suit the operator's preference allows for more effective use of the arm muscles, while placing less strain on the wrist and thumb.

PART NO.	DESCRIPTION
531C1-87	Regular Ergo-Handle
531C1-88	Cushion Ergo-Handle

Specialty Machines

Plastic Master Model 627PM/629PM

Eastman's Plastic Master has been specifically designed by Eastman's engineering group to eliminate the fusing of synthetic materials such as plastics, PVC, vinyl, and reinforced vinyl. Exclusively formulated Plastic Master Fluid is applied to a special wave blade by articulated arms. Gravity carries the Plastic Master Fluid down the blade and cools as it cuts. The Plastic Master option is available for dual-speed machines.

For more information on the Eastman Plastic Master 627PM/629PM, call your Eastman authorized dealer or Eastman factory direct.

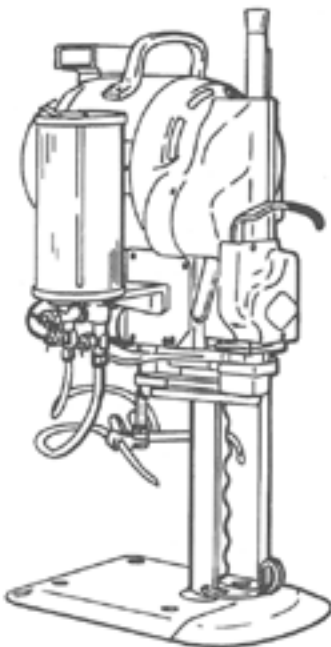

Figure 18. Plastic Master

Micro Fog Model 627MF/629MF

Eastman's Micro Fog is designed for the same purpose as the Plastic Master, but is more comprehensive. The exclusive Micro Fog and a 90-120 psi compressed air hose sends a mist of coolant/lubricant behind the knife and out through special slotted wave blades to penetrate every layer of cloth and eliminate the conditions that cause fusing. Micro Fogs are only available with dual-speed motors, 6" standards, and in 1-1/8 or 1-1/4 stroke only. Special waterproof belts are available for use on this machine. The amount of spray may be regulated through a valve on the device.

For more information on the Eastman Micro Fog 627MF/629MF, call your Eastman authorized dealer or Eastman factory direct.

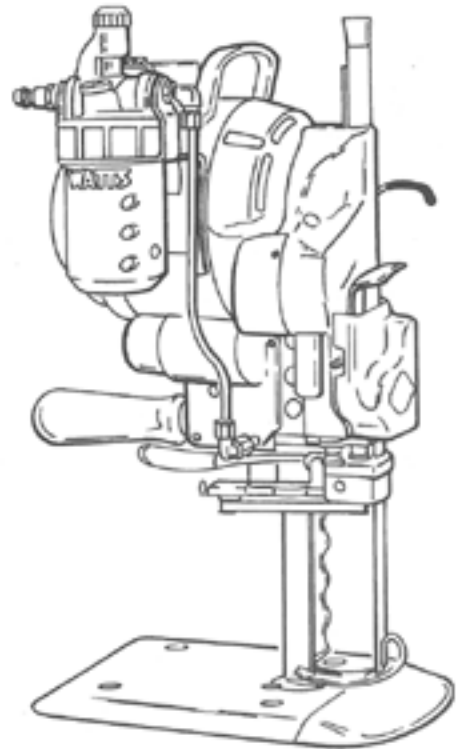

Figure 19. Micro Fog

Eastmanmachine
COMPANY

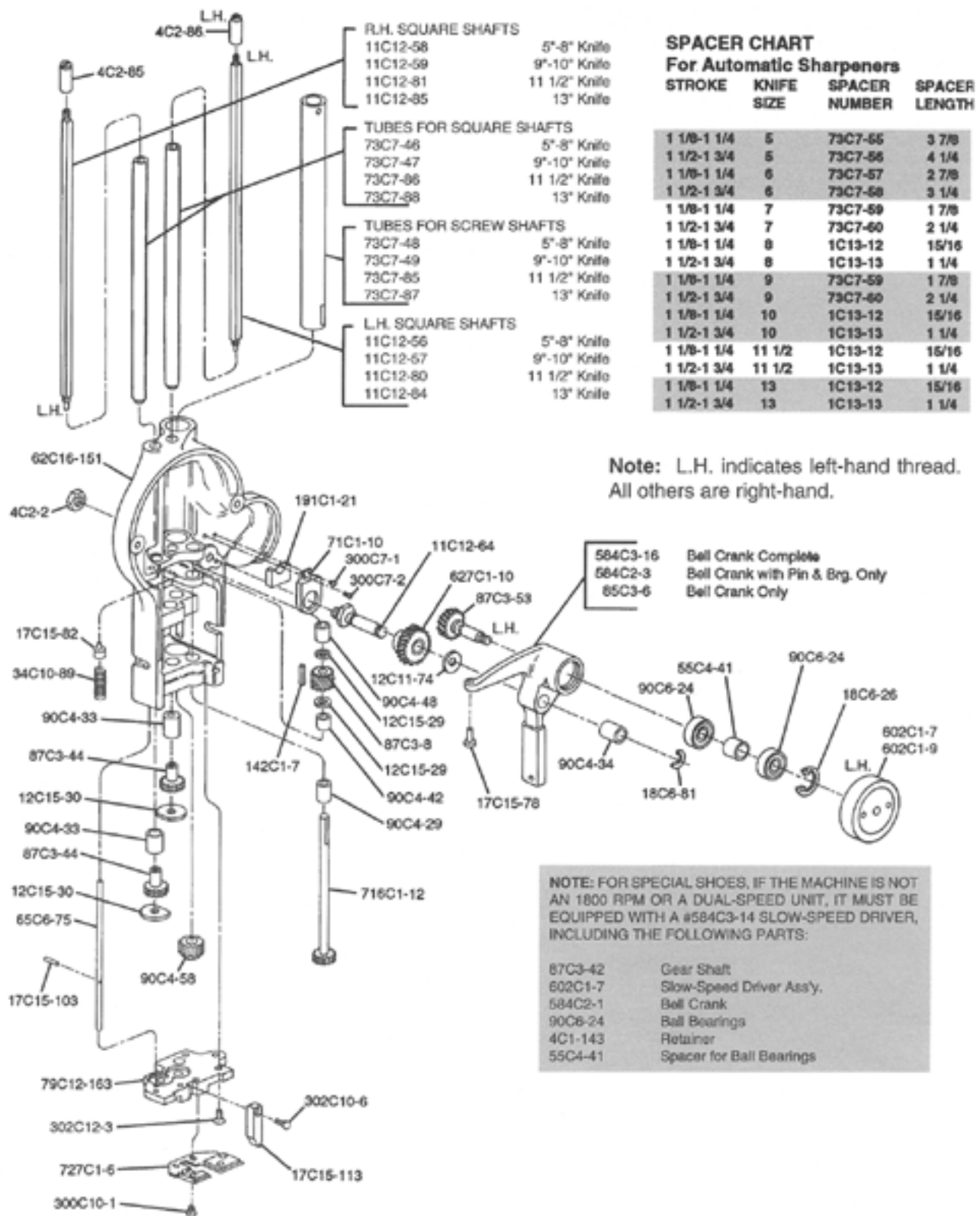

Figure 29. Sharpener Housing Assembly (Exploded, Rear View)

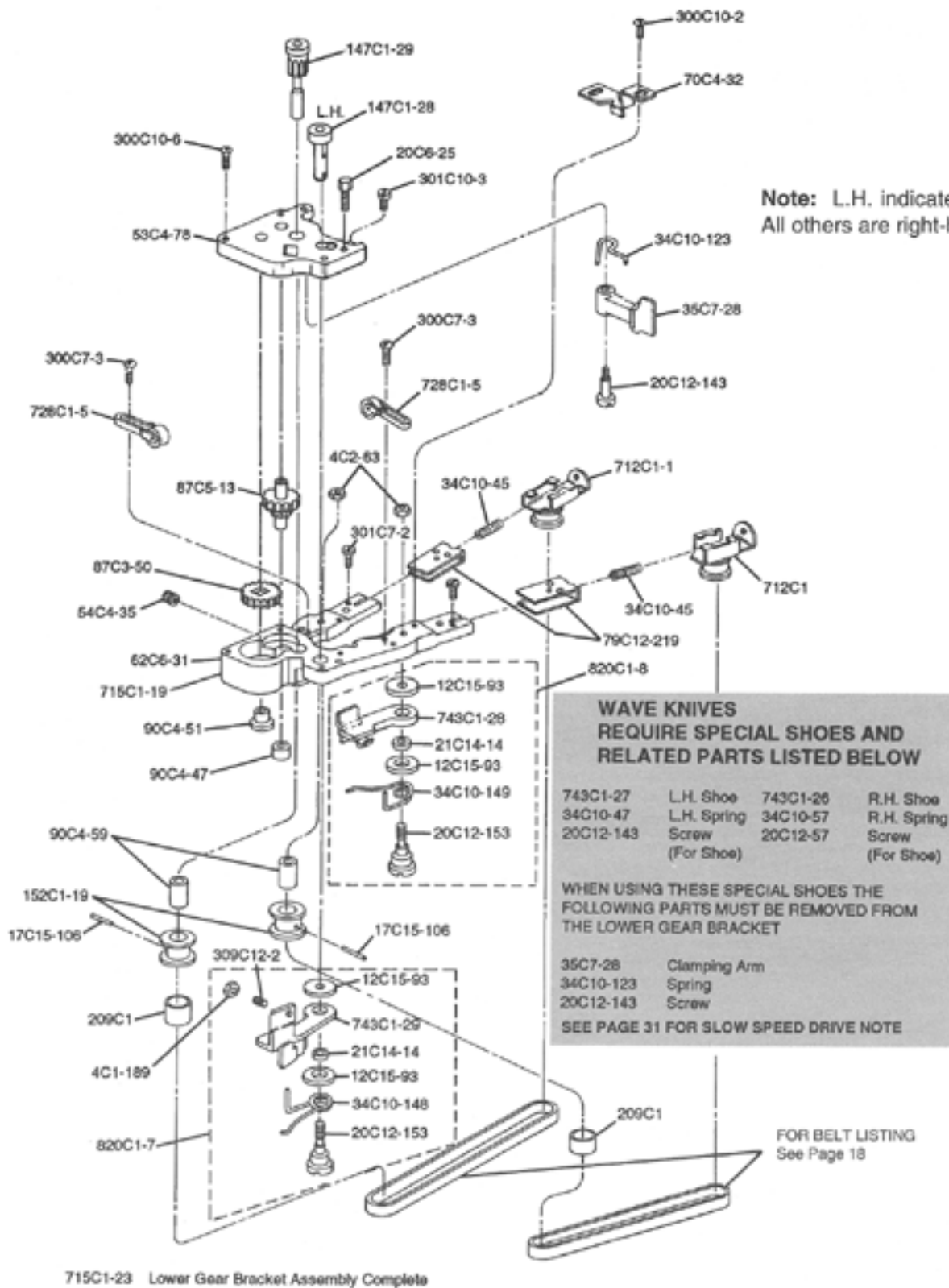

Figure 31. Lower Gear Bracket Assembly (Exploded View)